

1. General Specifications

Processor	Cortex-A8 32-Bit RISC
	303MHz
	DDR3 256M Byte
	128M Byte
	Yes
	Yes
	3
	RJ45 can be connected to expand the temperature and humidity, water immersion, SMS alarm module

2. Power supply specification

Input information	Range	Rated	Minimum	Maximum
DC input voltage		12V	9.6V	14.4V
DC input current		500mA	/	/

3. Pin assignment

Pin definition	Input and output information	Description
P1 GND	GND	Ground wire
	Input	DC power input
	Output	RS232 signal output
	Input	RS232 signal input
	GND	Ground wire

4. Environmental specifications

Parameter	Minimum temperature	maximum temperature
		70
		85
		90% RH
		95% RH

5. Dimension and appearance

Dimension	
	Dedicated card slot for 26 pins

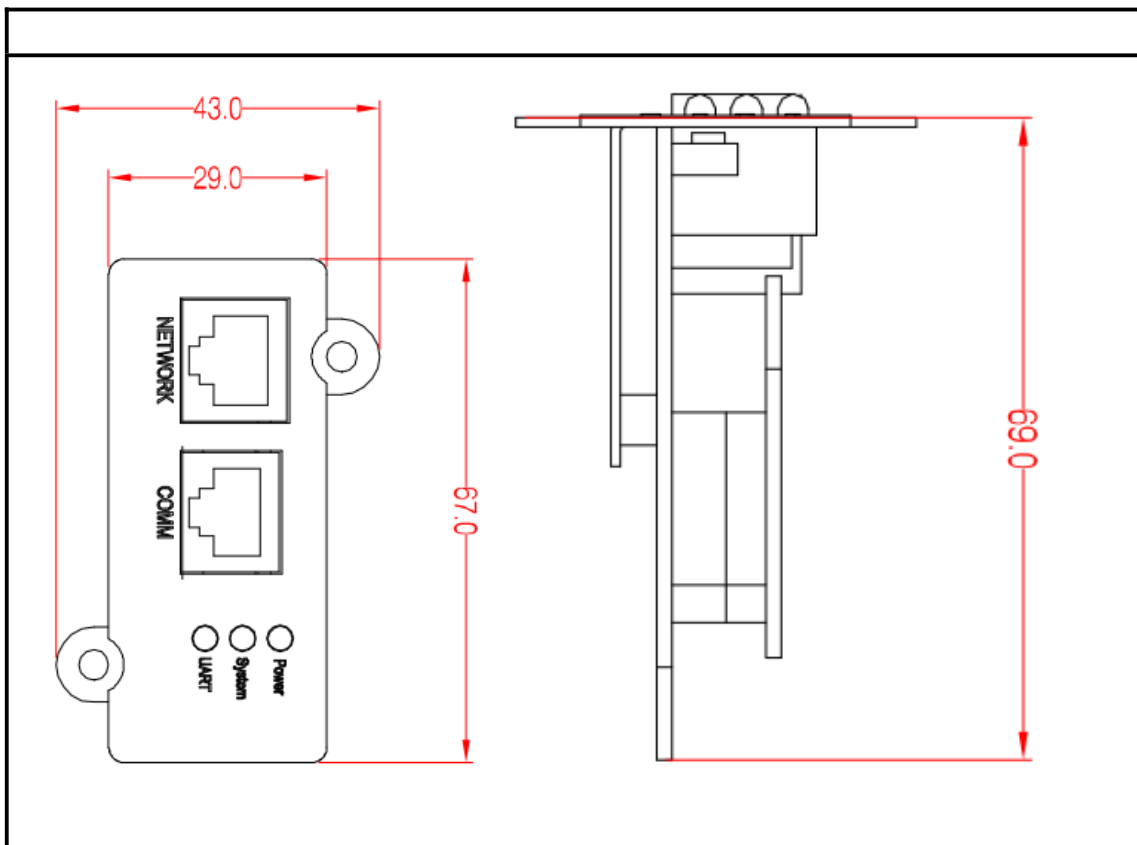

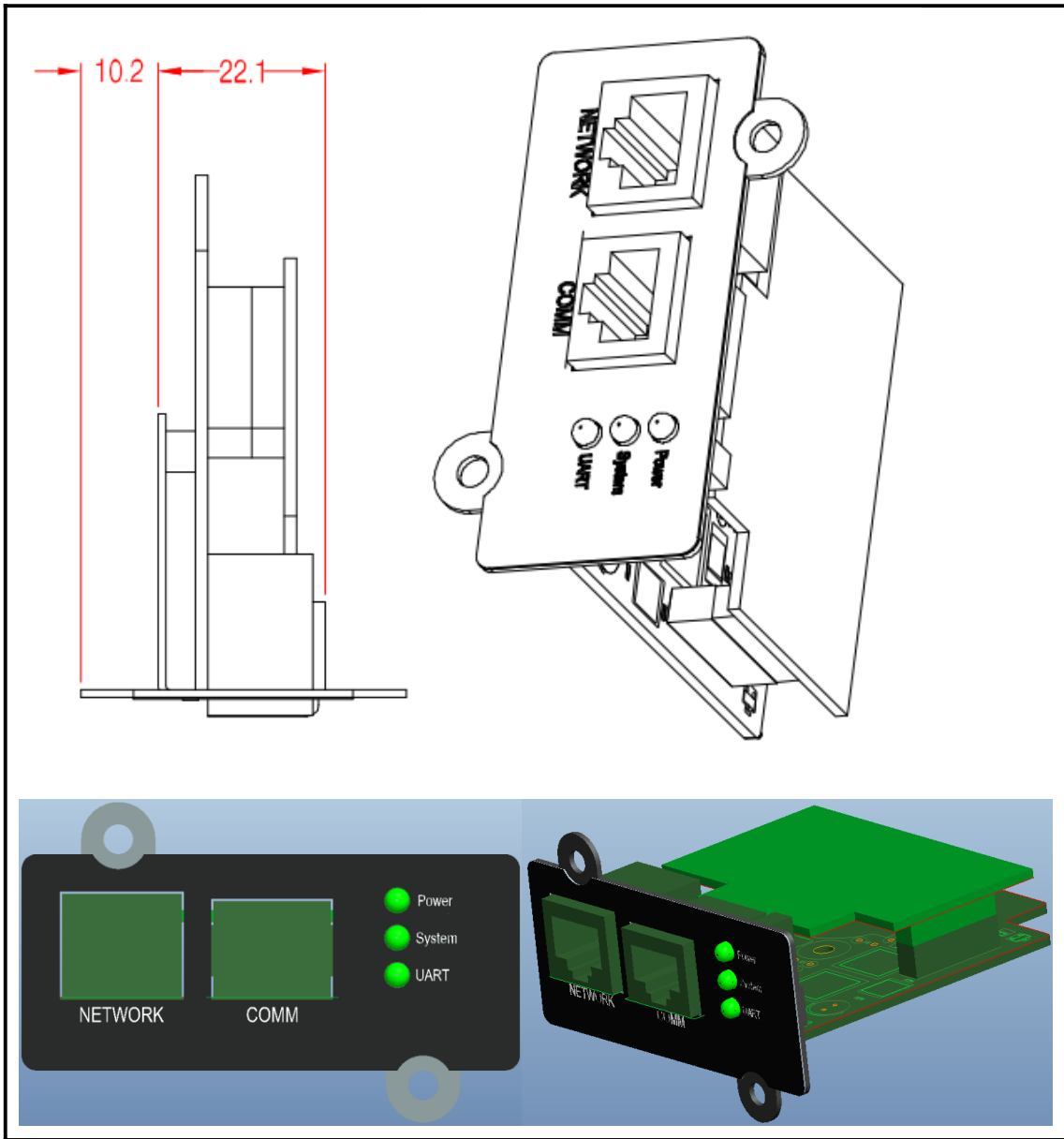

Appearance drawing

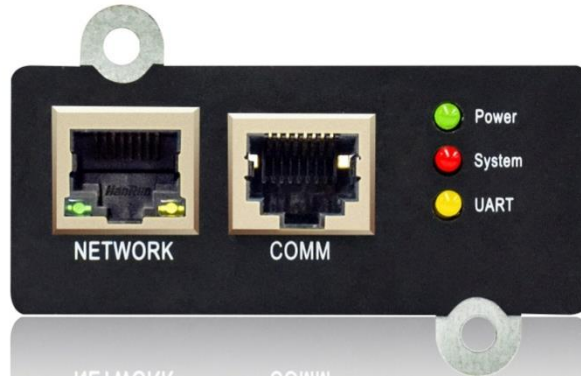

Top, bottom

